

The Kinney convoluted flexible connectors with rugged stainless steel bellows ease alignment problems and virtually eliminate transmission of vibration from other equipment. They are designed and fabricated to give years of trouble-free service.

Flanges are available in any combination. Standard units are supplied with both end flanges flat-faced. All flanges are ANSI standard and assure vacuum-tight sealing. These units can be supplied in other special combinations. Bellows are free-formed to assure uniform wall thickness and absence of metal scoring to prevent stress concentration. Stainless steel bellows also make these units suitable for use under a wider range of temperature conditions. Connectors are available for every vacuum application. Standard sizes are 1 1/2" through 8" diameter, and larger sizes are available upon request. Full conductance is assured because the I.D. of these bellows is larger than the O.D. of respective pipe sizes.

Kinney offers the best combination of features available. Kinney connectors are designed, manufacturer tested, and certified under strict quality control to assure long service.



**Flange-to-Flange Straight Connector**

**Features**

- Variety of sizes and combinations
- Dampens noise and vibration
- Makes installation easier and economical
- Compensates for misalignment, expansion, and contraction

**Materials of Construction**

- Standard with carbon steel flanges and 321 Stainless Steel bellows
- All stainless steel versions are also available (consult factory)

**Dimensions**

Values shown are approximate and should not be used for construction. Certified drawings are available through your local Tuthill Vacuum & Blower Systems Sales Professional.

**Thread-to-Flange Straight Connectors**

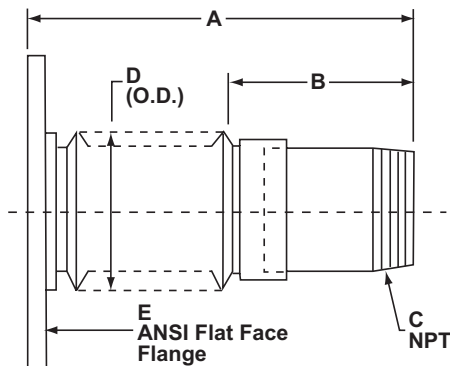

PIPE SIZE	FITS KINNEY MODEL	DIMENSIONS INCHES					MAX INTERNAL PRESSURE	RATED DEFLECTION	
		A	B	C	D	E		AXIAL	LAT
1½	KD-30A KD-50	7.00	3.875	1.5-11.5	2.72	1.5	80	.50	.50
2	KC-15 KTC-21	7.50	4.00	2-11.5	3.10	2	60	.60	.22

**NOTES:**

- Maximum Internal Pressure rating is based upon both ends of the connector being restrained.
- Combined axial and lateral movements cannot exceed 100%.

**EXAMPLE 1:** 75% axial rating +25% lateral rating.  
**EXAMPLE 2:** 20% axial rating +80% lateral rating.

## Dimensions

Values shown are approximate and should not be used for construction.  
 Certified drawings are available through your local Tuthill Vacuum & Blower Systems Sales Professional.

## Flange-to-Flange Straight Connectors

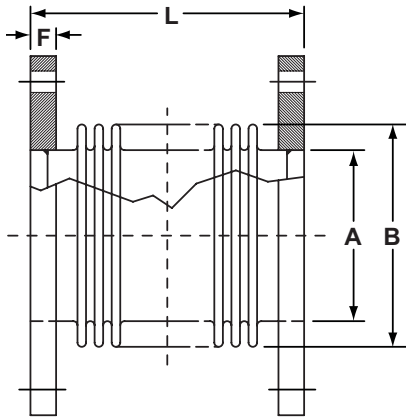

PIPE SIZE	FITS KINNEY MODEL	DIMENSIONS INCHES				MAX INTERNAL PRESSURE	RATED DEFLECTION	
		Ø A	Ø B	L	F		AXIAL	LAT
1.5"	CONSULT FACTORY	1.939	2.54	5.00	.50	80	.50	.20
2"	KDH-65 KDH-80	2.419	3.10	5.50	.50	60	.60	.22
3"	KDH-130 KDH-150 KT-150	3.559	4.37	6.00	.50	60	.70	.25
4"	KTC-225 KT-300	4.575	5.55	6.80	.50	50	.80	.25
6"	KT-500	6.721	7.97	8.88	.56	40	1.25	.32
8"	KT-850	8.747	10.07	9.50	.56	40	1.30	.32

**NOTE:** Maximum Internal Pressure rating is based upon both ends of the connector being restrained.

## Right Angle Connectors

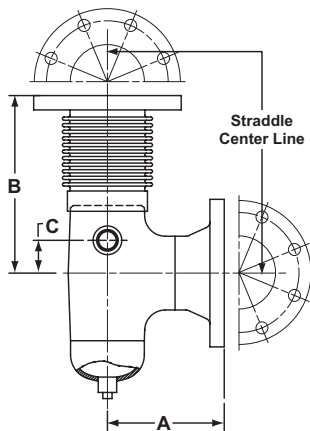

PIPE SIZE	FITS KINNEY MODEL	DIMENSIONS INCHES		
		A	B	C
3"	KTC-60 KTC-112 KT-150	6.12	9.14	1.50
4"	KTC-225 KT-300	7.13	10.83	2.00
6"	KT-500	9.12	13.77	2.50
8"	KT-850	11	15.75	3.50

## CONTACT US

For more information, contact your  
 Regional Sales Manager or call us at:

**1-800-825-6937**

Your Local Sales Professional: